

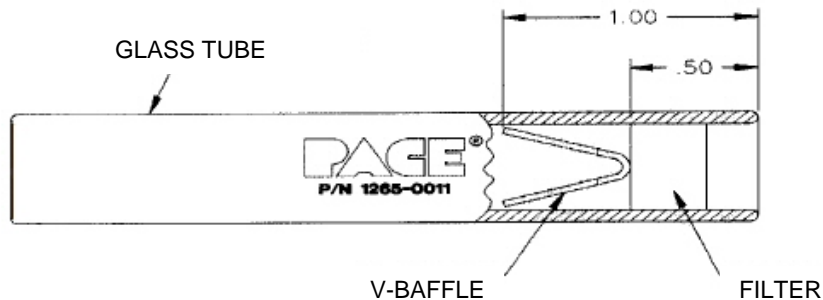

SX-80 GLASS FLUX / SODR TRAP INSTALLATION INSTRUCTIONS
PACE PART NUMBER 6000-0212-P1
MANUAL NUMBER 5050-0504 REV. C

WARNING: THE GLASS CHAMBER WILL BE HOT AFTER USE. USE THE RUBBER REMOVAL PAD TO HANDLE THE CHAMBER AT ALL TIMES AND ALLOW THE CHAMBER TO COOL BEFORE CLEANING. FAILURE TO DO SO MAY RESULT IN BURNS.

1. Packing Content:



PART NUMBER	DESCRIPTION	QUANTITY
1125-0011-P1	Glass Chamber, SX-80	2
1213-0087-P1	Front Seal	2
4010-0110-P2	V Baffle, Glass Chamber	2
1309-0018-P__*	Filter, Felt	4
1100-0307-P1	Hot Grip Removal Pad	1
* Item 1309-0018 is available in quantities of 10 (P10) or 100 (P100) each. Add P10 or P100 to part number when ordering.		

2. Installation

The following instructions provide the user with the information necessary to install the PACE SX-80 GLASS FLUX / SOLDR TRAP (P/N 6000-0212-P1). Perform the following procedure step by step, in sequence, to obtain proper results:

- A. While holding the SX-80 handpiece straight up with tip pointing up, pull plunger lock back until you can turn counter clockwise to loosen, release.
- B. Using recessed finger grips next to the PACE logo, pull flux /sodr trap door up and out.
- C. Remove cardboard disposable flux/sodr trap from holder.
- D. Insert the v-baffle followed by the felt filter into the glass chamber (align the felt filter to the blue marking; refer to assembly diagram in table above). Make sure the filter and the v-baffle have a small space between them.
- E. Check the front seal inside handpiece at the heater assembly for damage. If necessary, replace front seal.
- F. Insert glass flux/soldr trap into holder. Felt filter end is in the opposite direction of the arrows. Make sure end with filter is flush with the flux/soldr trap holder.
- G. Insert flux/soldr trap holder back into the SX-80.
- H. Turn plunger lock clockwise and lock into place.

3. Maintenance

Maintenance should only be completed by qualified personnel designated by your company. Clean glass flux/solder trap when it becomes filled with solder or you lose suction

- A. While holding the SX-80 handpiece straight up with tip pointing up, pull plunger lock back until you can turn counter
- B. Using recessed finger grips next to the PACE logo, pull flux/solder trap door up and out.
- C. Using new glass tube, push the used glass tube out of the flux/solder trap from holder onto a heat protected surface. Always use the rubber removal pad to pick up the hot glass tube to prevent burns.
- D. Allow glass tube to cool before cleaning.
- E. When chamber is cool push the v-baffle and filter out with a nylon bristle brush. DO not do this when hot, the nylon brush bristles will melt.
- F. Clean the chamber with the nylon bristle brush wetted with an approved solvent. Run the brush through the chamber several times till all solder and flux residue is completely removed. Coat the glass chamber and v-baffle with a small amount of mineral oil.
- G. Reassemble the collection chamber and by reinserting the v-baffle and a new felt filter.
- H. Inspect the front and rear seal for damage before reassembly.

4. Service

Any questions regarding the following instructions, contact your local authorized PACE dealer or contact PACE directly at:



PACE Incorporated
9030 Junction Drive
Annapolis Junction,
MD 20701
Tel: (301) 490-9860
Fax: (301) 498-3252

PACE Europe Limited
13 Tanners Drive
Blakelands
Milton Keynes
Tel: (44) 1908-277666
Fax: (44) 1908-277777